

## EXHAUST FAN WITH LED CCT LAMP

### SXIM-XF-02



Designed for efficient ventilation, this exhaust fan features a compact structure built with durable ABS panel and PP body. Its energy-saving 12W motor delivers stable high-speed performance at 1200 r/min, ensuring effective air circulation with an airflow capacity of 120 m³/h. Ideal for maintaining fresh and clean environments in residential and commercial spaces.

#### FEATURES

- Energy-saving 12W motor
- High airflow performance
- Durable ABS front panel
- Resistant PP body structure
- Low noise operation
- Stable high-speed rotation
- Easy installation
- Modern compact design

#### APPLICATION

- Bathrooms
- Kitchens
- Laundry areas
- Offices
- Storage rooms
- Commercial spaces
- Small warehouses

**CE IP20**

#### PHYSICAL DATA

Finish	White
Protection Level - IP	IP 20
Installation Size	200mm x 200mm
Type of Installation	Ceiling Mounted
Panel Material	ABS
Body Material	PP
Motor Type	DC

#### ELECTRICAL DATA

Input Power	23W
Energy Saving	YES
Operating Voltage	80-245V~
Frequency	50-60 Hz
Air Flow	120 m³/h
Fan Speed	1300 r/min

#### DIMENSIONS

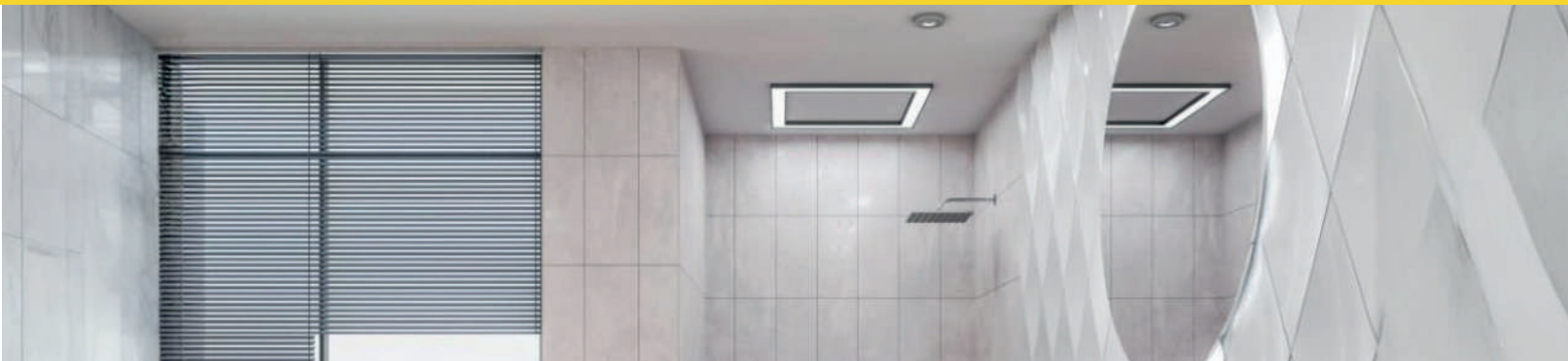
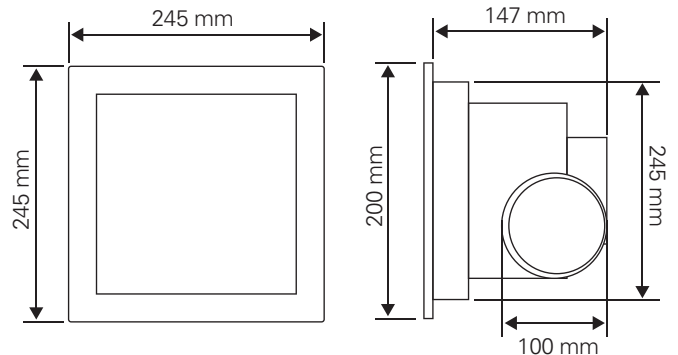

**THE MEASURE OF A PRO™**