

## EXHAUST FAN

### SXIM-XF-05



Designed for efficient ventilation in compact spaces, this 6-inch exhaust fan is powered by a high-efficiency DC motor with double ball bearing system for smoother rotation and extended lifespan. The 100% copper wire coil ensures superior electrical conductivity, energy efficiency, and stable performance for continuous air extraction.

#### FEATURES

- High-efficiency DC motor
- Double ball bearing system for durability
- 100% copper wire motor coil
- Energy-saving performance
- Stable and low-noise operation
- Compact square design
- Easy wall or ceiling installation

#### APPLICATION

- Bathrooms
- Small kitchens
- Laundry areas
- Offices
- Utility rooms
- Storage spaces

**CE** **IP20**

#### PHYSICAL DATA

Finish	White
Protection Level - IP	IP 20
Installation Size	150x150mm
Type of Installation	Ceiling Mounted
Panel Material	ABS
Coil Material	Double Ball Bearing Copper
Motor Type	DC

#### ELECTRICAL DATA

Input Power	8W
Energy Saving	YES
Operating Voltage	80-245V~
Frequency	50-60 Hz

#### DIMENSIONS

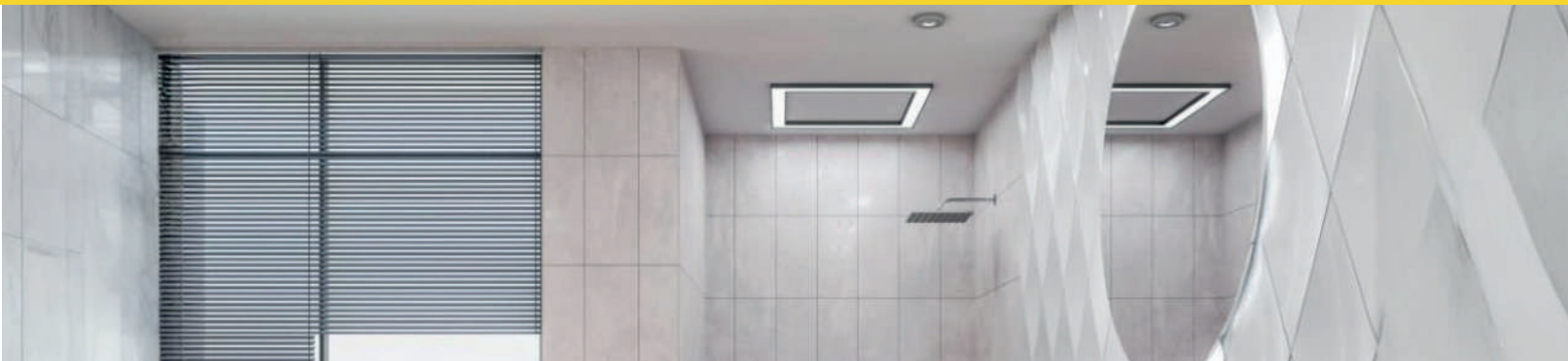
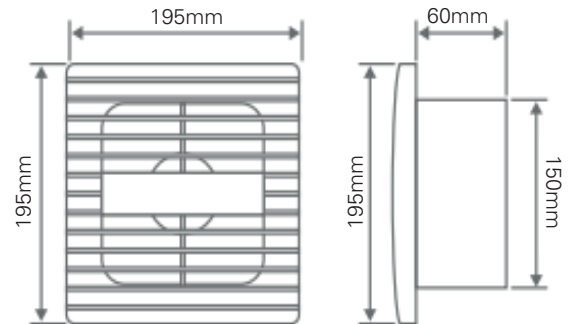

**THE MEASURE OF A PRO™**