

EXHAUST FAN WITH LED LAMP

SXIM-XF-04



This 8-inch exhaust fan combines high-efficiency ventilation with integrated lighting functionality. Equipped with a DC double ball bearing motor and 100% copper wire coil, it ensures smooth operation, low noise, and extended service life. The built-in 3CCT selectable lighting system allows users to adjust color temperature according to their environment needs, making it ideal for modern residential and commercial applications.

FEATURES

- High-efficiency DC motor
- Double ball bearing system for extended durability
- 100% copper wire coil for superior conductivity
- Wide voltage compatibility (85–245V)
- Integrated 3 CCT lighting selection
- Stable, low-noise performance
- Modern square design

APPLICATION

- Bathrooms
- Kitchens
- Laundry rooms
- Offices
- Commercial spaces

CE **IP20**

PHYSICAL DATA

Finish	White
Protection Level - IP	IP 20
Dimensions	8" (200mm)
Type of Installation	Ceiling Mounted
Panel Material	ABS
Coil Material	Double Ball Bearing Copper
Motor Type	DC

ELECTRICAL DATA

Input Power	23W
Energy Saving	YES
Operating Voltage	85-245V~
Frequency	50-60 Hz
CCT	3000K, 4000K, 6500K

DIMENSIONS

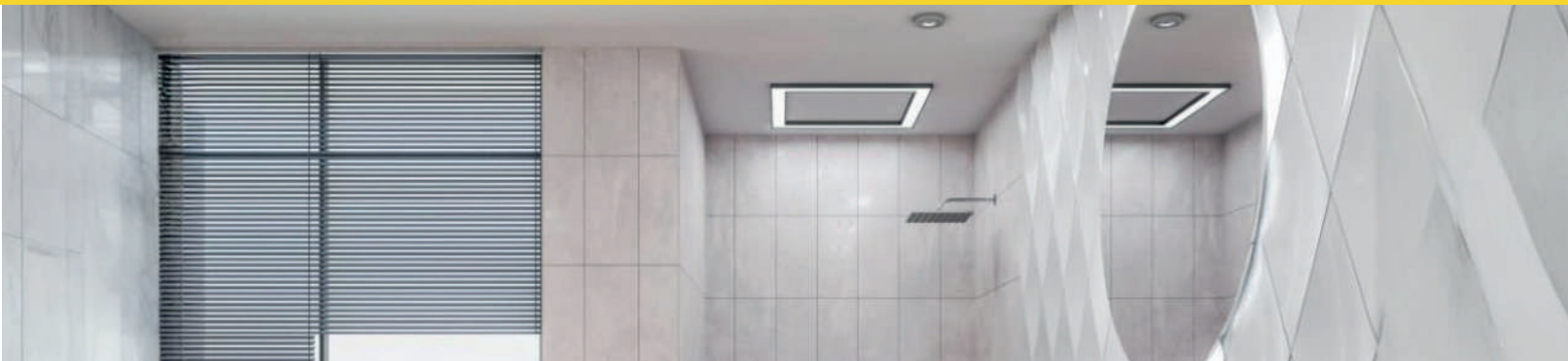
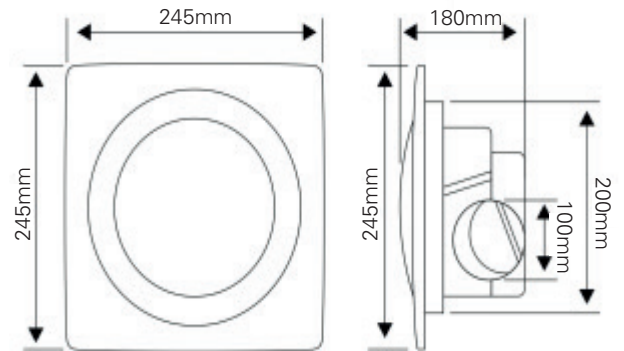

THE MEASURE OF A PRO™